

Mixing and pumping in one system: **Lutz DDP Mixing System**



For liquids which have to be mixed prior to processing and then pumped or which are containing small solids, the new DDP mixing system with an integrated air-operated doubled diaphragm pump from Lutz is the perfect solution.

The mixing and pumping process is made via a suction and mixing tube and a 3-way tap. The pre-assembled system is immediately ready for use with a few simple steps and is also suitable for explosive liquids.

Features & Benefits:

- Mixing and pumping in one system
- Also suitable for higher viscosities and liquids containing solids
- Quick installation and time saving thanks to easy handling
- No additional mixer necessary
- Compact design
- Easy to insert into the 2" bung hole of the container using a hoist or an indoor crane
- Base plate offers a good stability on the container lid

Examples of liquids:

Paints and varnishes, emulsions, dispersions, suspensions, water/oil mixtures, liquids with increased viscosity and solids content



**System is
already
delivered
pre-assembled!**

NEW!



Technical data

Pump	Compressed air-operated double diaphragm pump mounted on a base plate
Housing material	Stainless steel (1.4404)
Diaphragms, check balls, seals	PTFE
Ex-identification	Ex II 2 GD c TX
Hoses:	Universal chemical hose 3/4" bound
Delivery rate	max. 57 l/min.
Operating pressure	max. 8.2 bar
Temperature	max. 93 °C
Solids up to	max. ø 3,2 mm
Connection on the pressure side of the ball valve	G 3/4 female
Dimensions:	approx. ø 550 x 1300 mm
Piping:	Stainless steel (1.4571)
Weight (including pump)	21 kg
Art. No.	5000-140

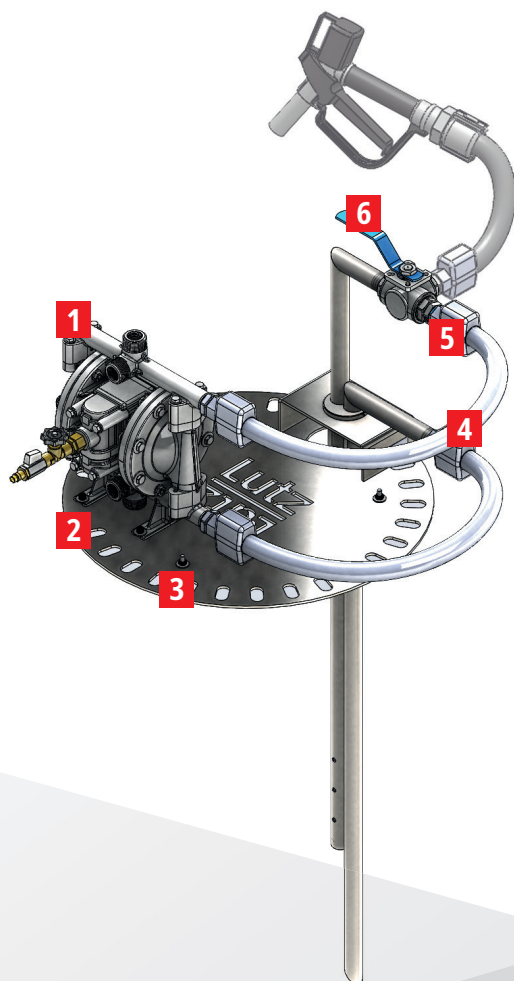

Accessories:

Wire rope suspension

Stainless steel, ø 4 mm, length approx. 700 mm
Art. No. 5000-144

Hoses, nozzles, discharge spouts and everything for compressed air supply see accessories programme DMP leaflet

- 1** Double diaphragm pump 1/2"
- 2** Vibration damper
- 3** Base plate
- 4** Universal chemical hose
- 5** Hose connection
- 6** 3-way ball valve G 3/4"